

STEP 7 - BRACING

Bracing is required on stages with a height greater than 30". Brace each corner and every third bay along each side. Internal braces should be placed in different rows than perimeter bracing to increase stability. Users may choose either horizontal or diagonal bracing. Follow the instructions below for the chosen bracing method.

Horizontal Bracing

- A) Determine what brace to use. A starter brace will connect two legs in the same deck. A continuous brace will connect a leg in one deck to a leg in the adjacent deck. Insert brace pins into stage legs.
- B) Turn bracket until it is perpendicular with the stage leg. Bracket lip should rest flush against the outer edge of the stage leg.
- C) Tighten the wing nut on the front of the horizontal brace to secure the bracket. Use two braces per bay and three braces per bay for heights greater than 48". Spacing between braces is a maximum of 24" and a minimum of 12".
- D) A common leg **must** be braced in two directions. Depending on the height of stage, adjacent braces may overlap **one** hole. Bracket lip should rest against the stage leg and **not** the adjacent brace.
- E) Repeat Steps until all bracing is thoroughly attached.

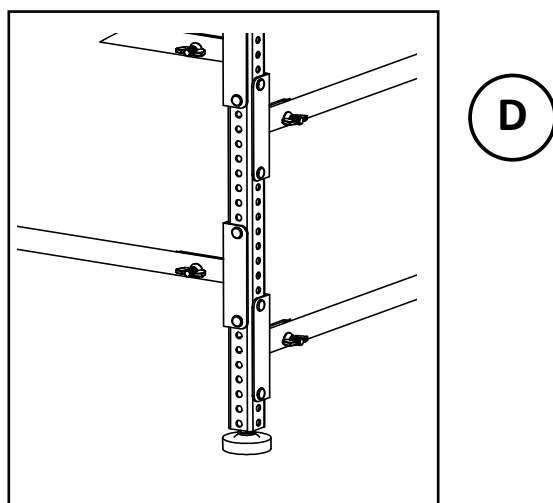
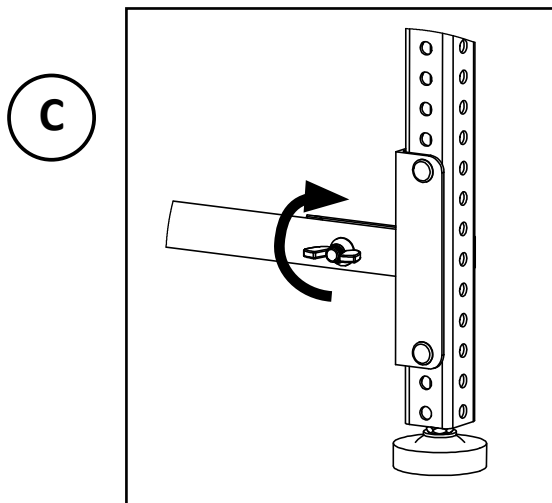
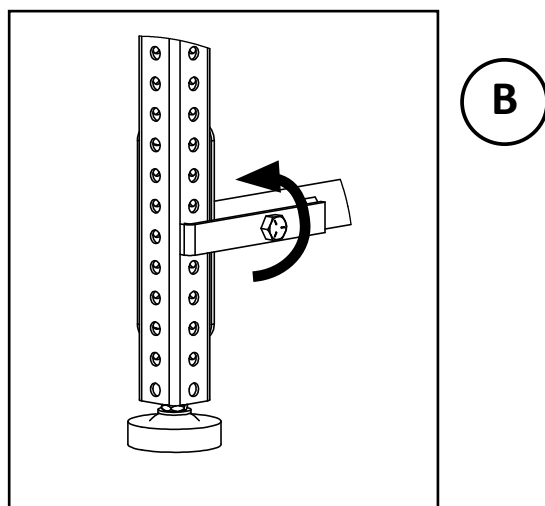
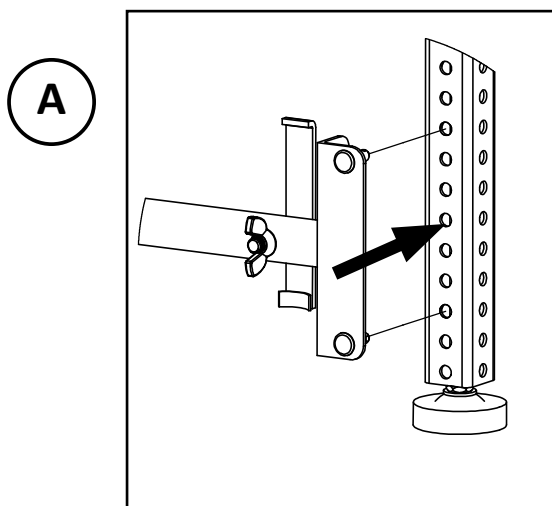

STEP 7 - BRACING (continued)

Diagonal Bracing

- A) A common leg **must** be braced in two directions. Position braces on leg height to maintain equal brace spacing. The bolt spacing of the diagonal braces will be: 12" with legs at 48" center line or 18" with legs at 46" center line.
- B) Attach brace with four $\frac{3}{8}$ " x 2-1/2" hex bolts and wing nuts.
- C) Use two braces per bay for heights greater than 48". If an adjustable leg is used, at least one of the braces should span the connection between the 1-1/2" leg and 1-3/4" sleeve.
- D) Repeat Steps until all bracing is thoroughly attached.

A

